

DOUBLE DIP OF

SMART DESIGN

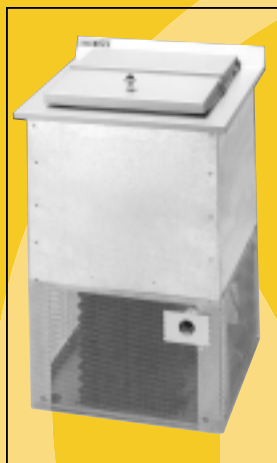

Model SKDI



Model SKFS



- Cold wall evaporator design
- Provides optimum dipping temperature
- Anti-condensation heater around top
- Prevents unwanted moisture formation

WE'VE GOT REFRIGERATION DOWN COLD™

ICE CREAM FREEZER SPECIFICATIONS

MODEL SKDI MODEL SKFS

INTERIOR	Stainless steel with covered corners for easy cleaning. Anti-condensation heater around top opening prevents moisture formation.
INSULATION	Environmentally friendly foamed -in-place polyurethane insulation for maximum efficiency, strength and durability.
REFRIGERATION	CFC-free, hermetically sealed, high efficiency, self contained refrigeration system with fan cooled condenser. Cold wall evaporator provides optimum ice cream dipping temperature. Adjustable temperature control.
ELECTRICAL	Standard as 115 volt, 60Hz, single phase operation, 7 foot power cord with NEMA 5-15P plug. Also available in 230 volt, 50Hz, single phase.
LISTINGS	ETL (U.S. and Canada), NSF International
WARRANTY	One year materials and workmanship warranty on cabinet and refrigeration system. Five year warranty on compressor.
SKDI (DROP-IN)	Heavy gauge, galvanized steel with welded angle frame and base assembly. Stainless steel top.
SKFS (FREE-STANDING)	Stainless steel outer shell. Adjustable 6-inch bullet type legs. Casters optional.

MODEL	OUTSIDE DIMENSIONS			STORAGE CAPACITY	AMPS	COMPRESSOR	SHIPPING WEIGHT
	HEIGHT	WIDTH	DEPTH				
SKDI	24 5/8" less lid	16 1/4"	16 1/4"	1 cu. ft.	1.8	1/8 hp	80 lbs
SKFS	30 5/8" cabinet	16 1/4"	18"	1 cu. ft.	1.8	1/8 hp	100 lbs



Specifications subject to change without notice.

Dimensions in inches and centimeters

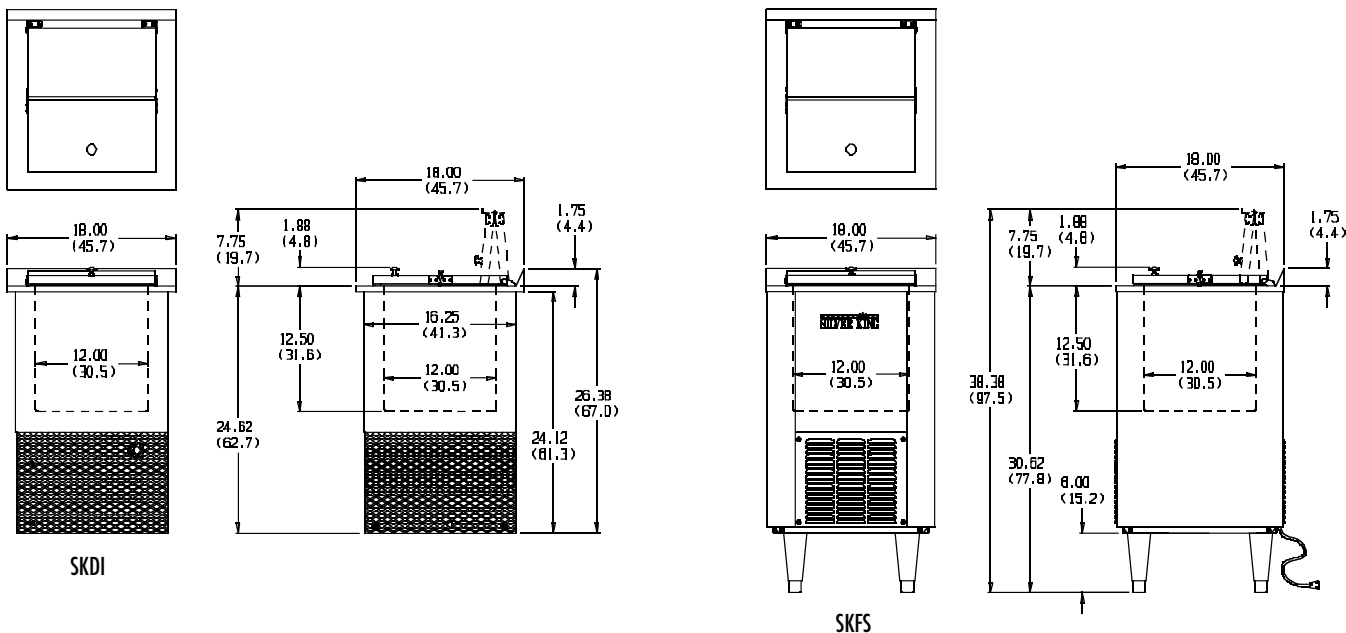

1600 Xenium Lane North
 Minneapolis, MN 55441-3787
 Phone (763) 923-2441
 Fax (763) 553-1209
 www.silverking.com

#FNSKFS02
 © Silver King 2002
 Printed in U.S.A.

DOUBLE SCOOP **OF QUALITY**



Model SKF52

- Efficient and durable cold wall design
- Provides optimum dipping temperature
- Stainless steel lid with heavy-duty hinges

ICE CREAM FREEZER SPECIFICATIONS

MODEL SKFS2	EXTERIOR	Stainless steel front, back and sides.
	INTERIOR	Stainless steel floor and sidewalls. Covered corners and finished edges for easy cleaning.
	INSULATION	Environmentally friendly foamed-in-place polyurethane insulation for maximum strength and durability.
	LID	Fully insulated stainless steel lid with heavy-duty hinges and handles.
	CASTERS	Supplied with heavy-duty casters, (two with locks), secured to 14 gauge steel base to ensure years of trouble free operation.
	REFRIGERATION	CFC-free, R-134a refrigerant, hermetically sealed, high efficiency, self contained refrigeration system with adjustable temperature control and manual defrost.
	ELECTRICAL	Standard as 115 volt, 60Hz, single phase operation. 8 foot, 3-wire power cord with NEMA 5-15P plug.
	LISTINGS	ETL (U.S. and Canada), NSF International
	WARRANTY	One year materials and workmanship warranty on cabinet. Five year warranty on compressor.

MODEL	OUTSIDE DIMENSIONS			STORAGE CAPACITY	AMPS	COMPRESSOR	SHIPPING WEIGHT
	HEIGHT	WIDTH	DEPTH				
SKFS2	37 3/4"	14 3/4"	23 3/4"	2.78 cu. ft.	1.6	1/10 hp	115 lbs



Specifications subject to change without notice.

Dimensions in inches and centimeters

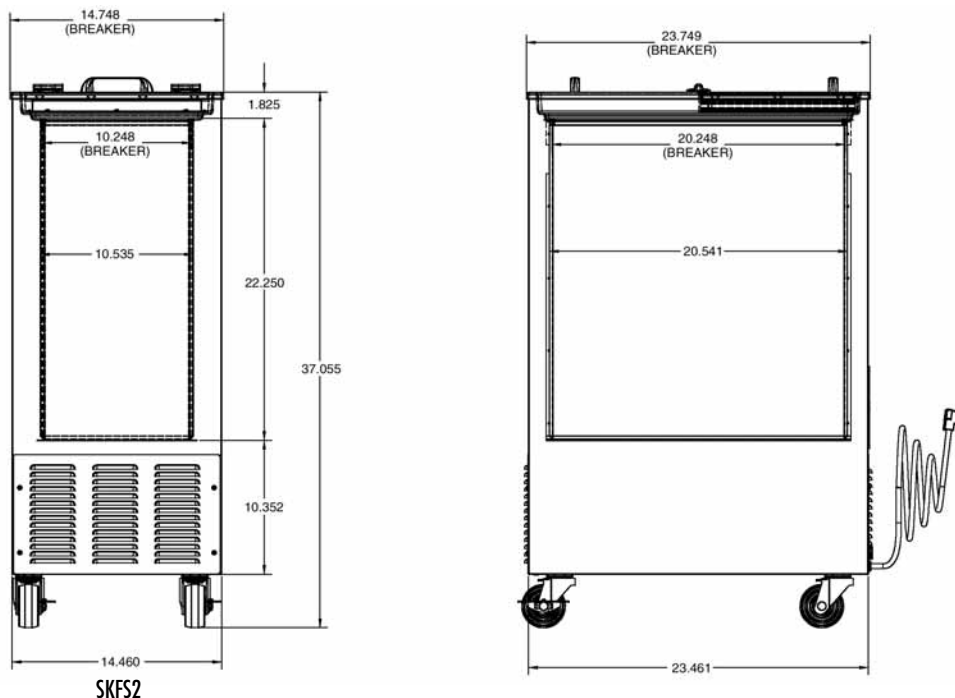

1600 Xenium Lane North
 Minneapolis, MN 55441-3787
 Phone (763) 923-2441
 Fax (763) 553-1209
 www.silverking.com

#FNSKFS207
 © Silver King 2007
 Printed in U.S.A.