

Halsey Taylor Owners Manual

Non-Refrigerated Freeze Resistant Fountains

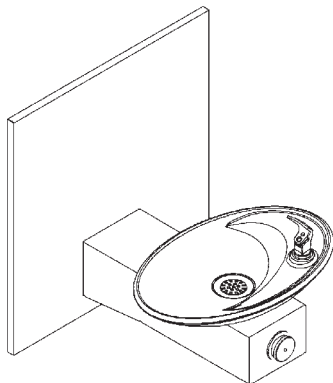

OVLEBPFR

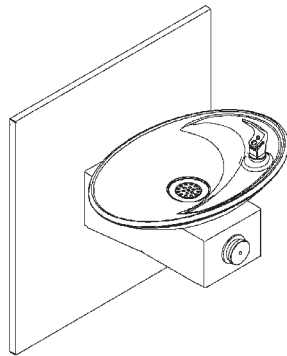

OVLSBPFR

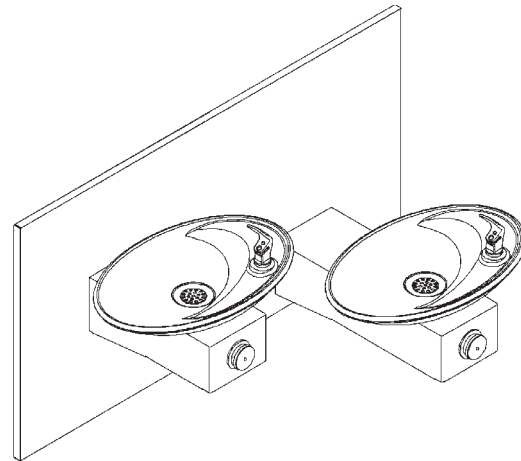

OVLSEBPFR

Installer

Halsey Taylor Fountains are among the easiest to install Fountains on the market today. To assure you install this model easily and correctly, PLEASE READ THESE SIMPLE INSTRUCTIONS BEFORE STARTING THE INSTALLATION. CHECK YOUR INSTALLATION FOR COMPLIANCE WITH PLUMBING, ELECTRICAL AND OTHER APPLICABLE CODES. After installation, leave these instructions with the Fountain for future reference. This Freeze Resistant Fountain(s) is shipped in two separate cartons. The second carton(s) contains the Freeze Resistant Package(s) **HTFRB1** that are installed on an interior heated wall. The interior space must maintain a minimum temperature of 50° F (10° C). Refer to the Freeze Resistant Package for the rough-in dimensions for installation.

IMPORTANT

ALL SERVICE TO BE PERFORMED BY AN AUTHORIZED SERVICE PERSON

IMPORTANT! INSTALLER PLEASE NOTE.

THE GROUNDING OF ELECTRICAL EQUIPMENT SUCH AS TELEPHONE, COMPUTERS, ETC. TO WATER LINES IS A COMMON PROCEDURE. THIS GROUNDING MAY BE IN THE BUILDING OR MAY OCCUR AWAY FROM THE BUILDING. THIS GROUNDING CAN CAUSE ELECTRICAL FEEDBACK INTO A FOUNTAIN, CREATING AN ELECTROLYSIS WHICH CAUSES A METALLIC TASTE OR AN INCREASE IN THE METAL CONTENT OF THE WATER. THIS CONDITION IS AVOIDABLE BY USING THE PROPER MATERIALS AS INDICATED. ANY DRAIN FITTINGS PROVIDED BY THE INSTALLER SHOULD BE MADE OF PLASTIC TO ELECTRICALLY ISOLATE THE FOUNTAIN FROM THE BUILDING PLUMBING SYSTEM.

OVL - EBPFR/SBPFR/SEBPFR COOLER INSTALLATION

The freeze resistant package must be mounted on an interior wall in a heated area. The room temperature of the interior heated area must be 50° F (10° C) or higher. The freeze resistant package may be surface or recessed mounted. If recess mounted the surface of the cover must be flush with the interior wall surface. The package is furnished with screws for mounting the cover to the box. If the box is recess mounted, do not fasten the top and bottom of the cover to the box. Use the holes on the front only.

1. Wall should already be framed for the fountain using the rough-in dimensions shown in Fig's. 1, 2, 3, 4, 5, or 6. Shown dimensions pertain to installation location (framing must support up to 150 Lbs. weight for single fountain and 300 Lbs. for dual fountains). These dimensions are required for compliance with ANSI Standard A117.1 and ADA (Framing shown for reference).
2. Attach wall plate assembly to wall as shown in Fig's. 3, 4, or 6 using 5/16" x 2" long bolts and flat washers (not provided). Tighten securely, (Fastener must match wall type, i.e. lag screws for wood studs, bolts and anchors for masonry construction).
3. Install back panel. Place the upper edge of the panel above hanger on the wall. Slide the panel down until it engages the hanger. Be sure back panel is firmly engaged before releasing it.
4. Remove bottom access panel from fountain basin and save screws. Install the fountain to the back panel and wall using (4) 5/16" x 3/4" long bolts and washers (provided) thru holes in back panel. A washer is used on the bottom two (2) holes only. Tighten securely.
5. Assemble the operating cable to the fountain bracket. (Fountain should be mounted to exterior wall) Create a loop in the cable and thread the free end of the cable through the wall into the freeze resistant box. The adjustment nuts should be in the middle of threaded area on the operating cable. See Figure 7.
6. Connect free end of operating cable to the valve-operating bracket. The end of the cables must be recessed into the indents on the pivot brackets. Remove cable free play by adjusting the jam nuts on the ends of the operating cable. See Figure 7.
7. Connect water line from fountain bubbler into freeze resistant box. The connection to the box uses a quick connect water fitting. Position the water line, in the fountain, to drain back into interior mounted box. Any water left standing, in the exterior line, can freeze. See Fig. 13.
To insert tubing, push tube straight into fitting until it reaches a positive stop. To remove tubing from the fittings, relieve water pressure, push in on dark gray collar while pulling out on the tubing. See Figure 12.
8. Connect drain and water supply lines to the freeze resistant fountain. Refer to Figure 1, 2, 3, 4, 5 or 6 for component positions. Inline strainer must be used on the inlet water line. See Fig. 11.

Start-up

1. Turn on building water supply and check all connections for leaks. Repair as required.
2. Stream height is factory set at 45-50 PSI. If stream height (See Fig. 14) needs to be changed adjust the regulator in the freeze resistant package. Clockwise adjustment raises stream height, counter clockwise adjustment will lower stream.
3. Adjust operating cable as required. Cable system should have a minimal amount of free play to allow for proper valve operation. If the system is too tight the valve will stay in the on position creating constant water flow. Too much free play will result in non-operation of the valve with the push-buttons.
4. Note: Water from the drain back tube in the freeze resistant package, will continue to run while the valve is actuated.
5. After cable system is adjusted properly stuff flexible insulation into any openings between the outside wall and the interior box.
6. Recheck all connections. If all connections are leak free replace cover(s) on the freeze resistant box(es) and fountain(s).

TOP VIEW ROUGH-IN FOR OVLSBPFR/OVLEBPFR

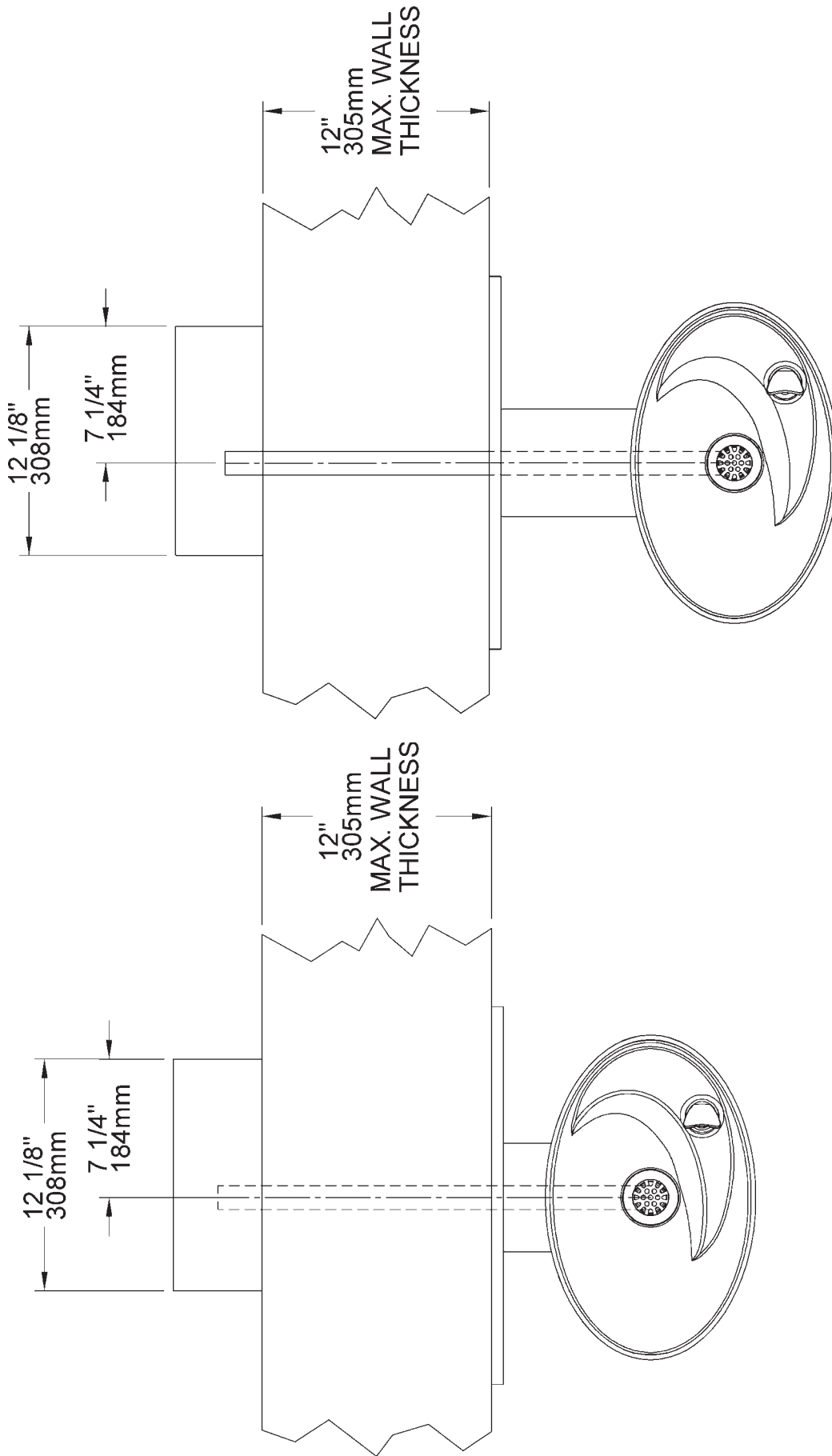

FIG. 1

FIG. 2

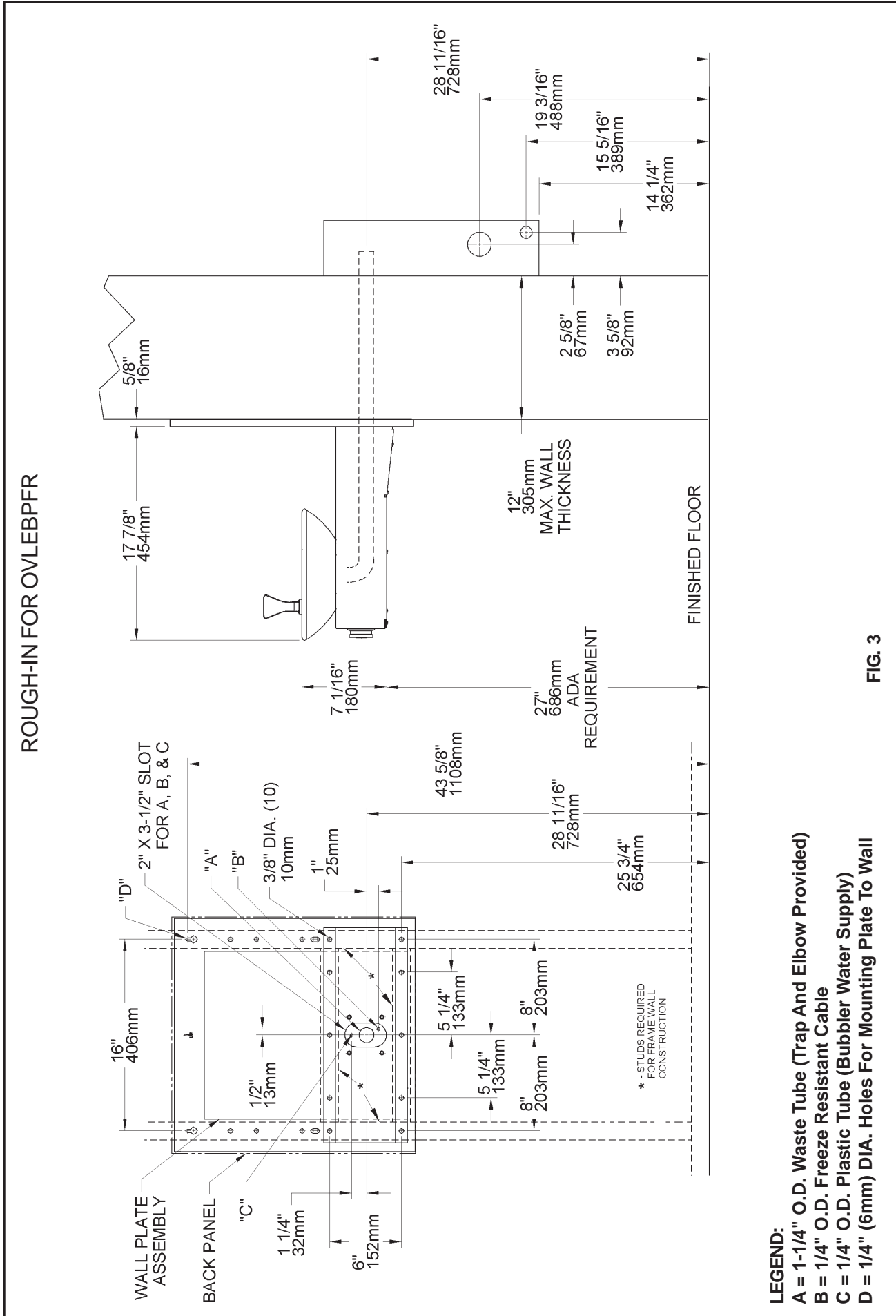

FIG. 3

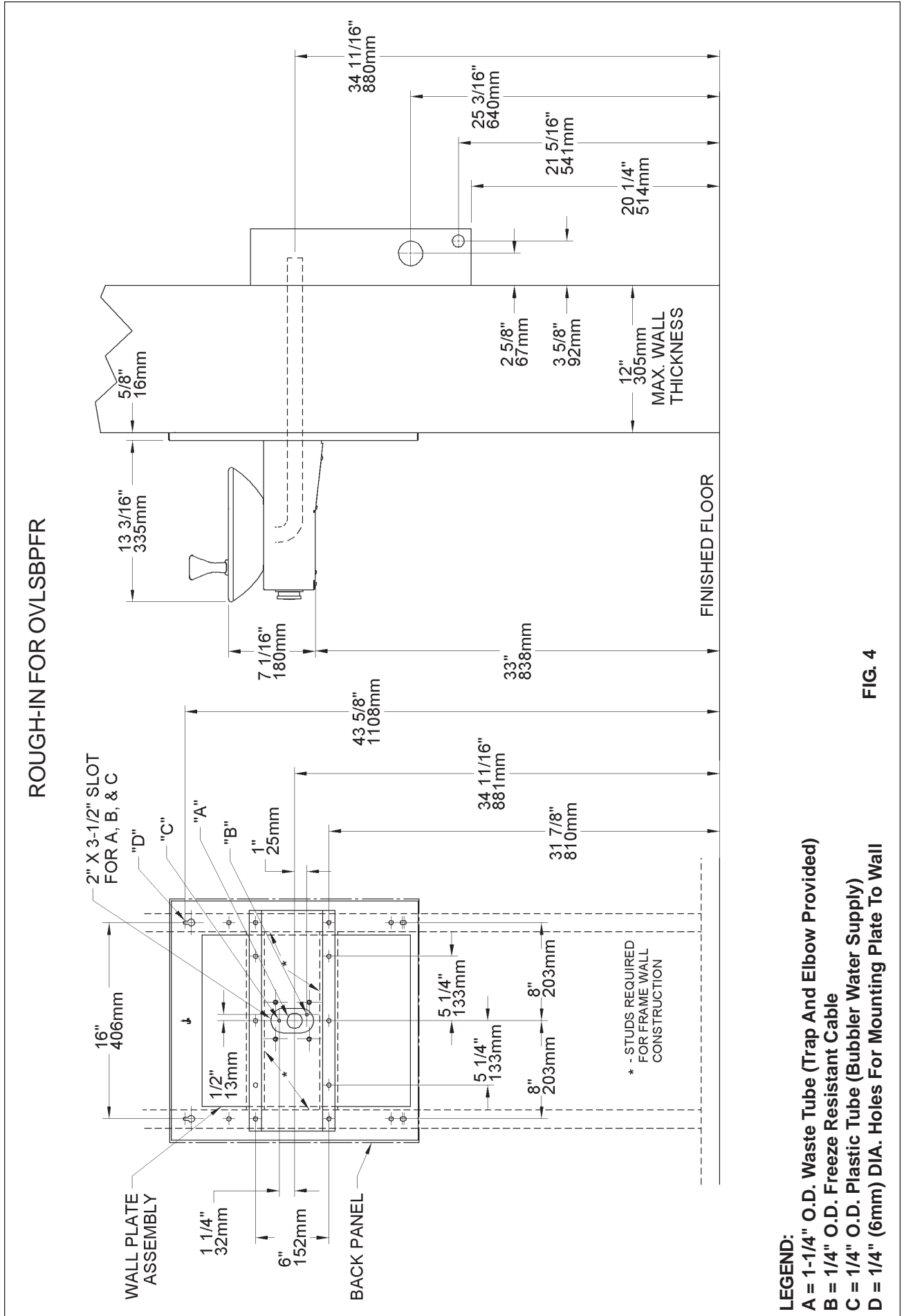

FIG. 4

LEGEND:
 A = 1-1/4" O.D. Waste Tube (Trap And Elbow Provided)
 B = 1/4" O.D. Freeze Resistant Cable
 C = 1/4" O.D. Plastic Tube (Bubbler Water Supply)
 D = 1/4" (6mm) DIA. Holes For Mounting Plate To Wall

TOP VIEW ROUGH-IN FOR OVLSEBPFR

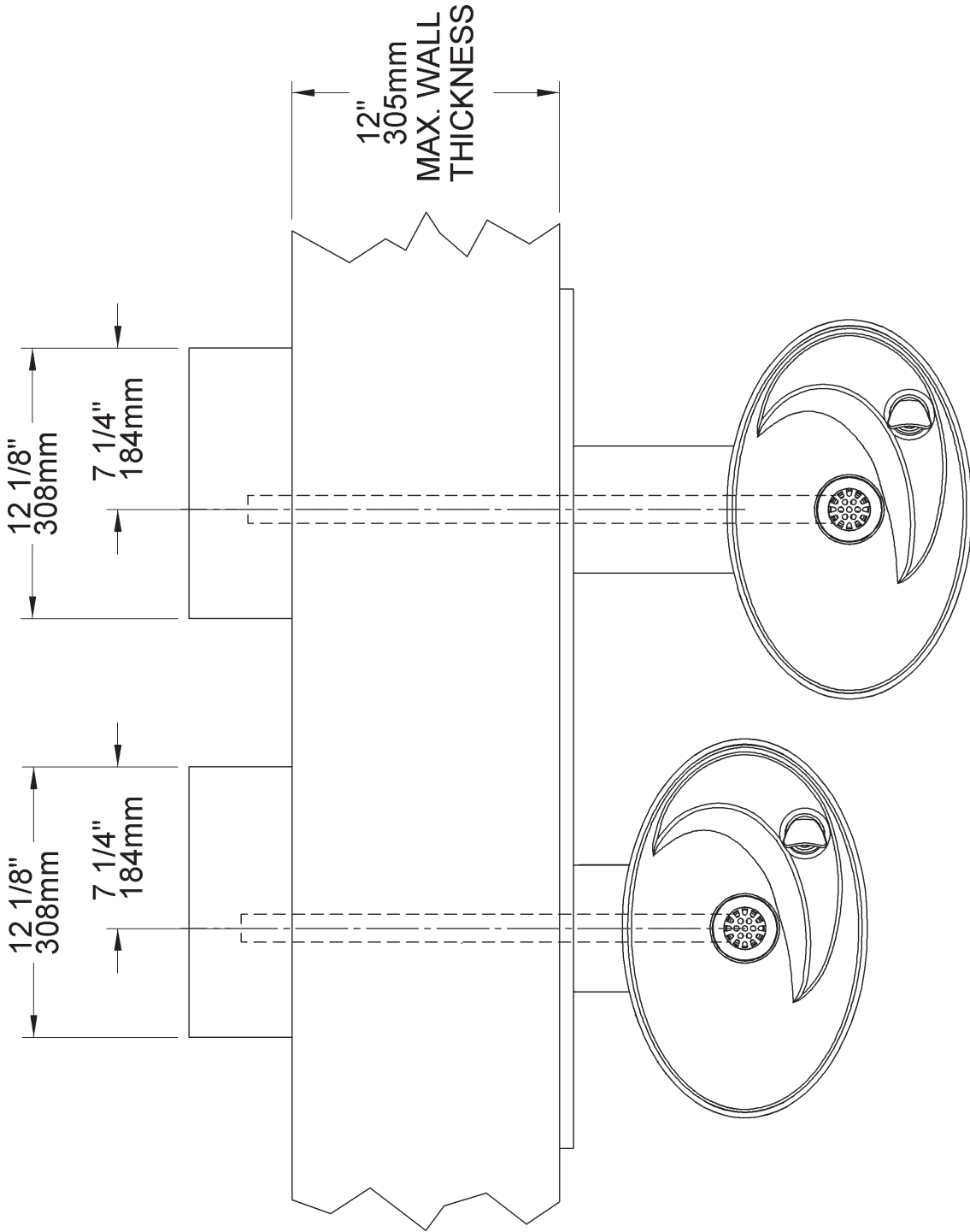

FIG. 5

ROUGH-IN FOR OVLSEBPFR

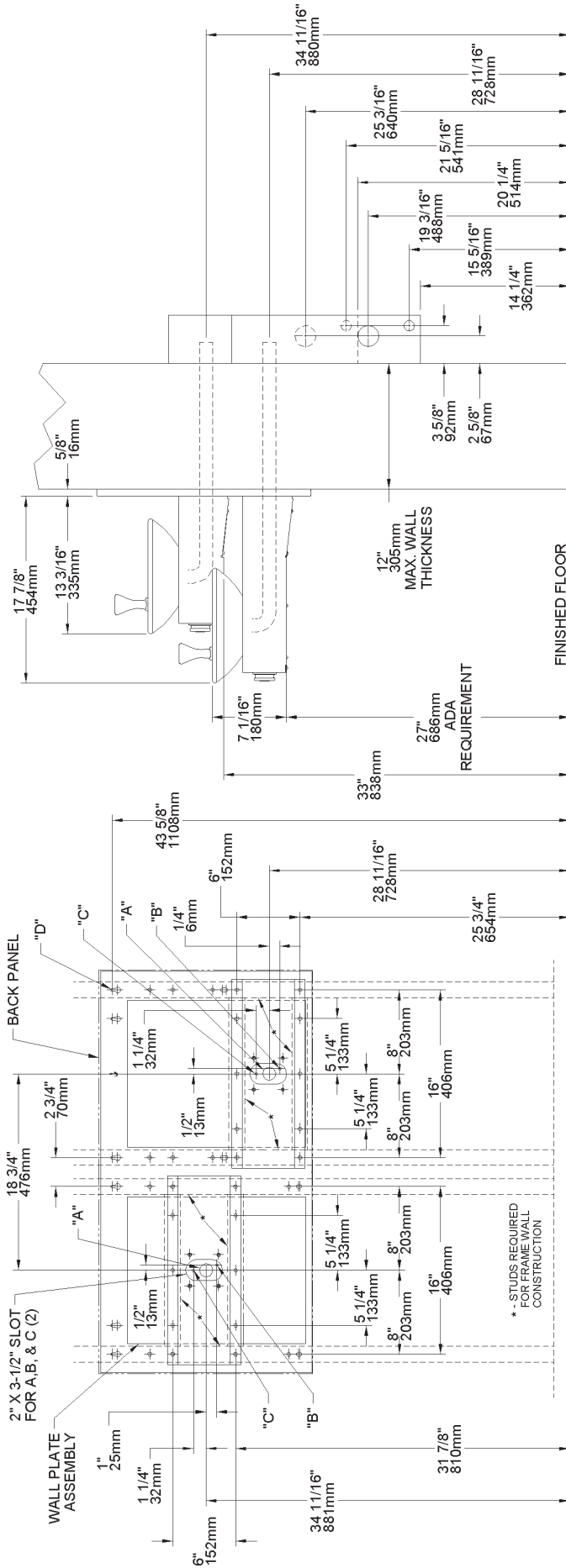

FIG. 6

- LEGEND:**
 A = 1-1/4" O.D. Waste Tube (Trap And Elbow Provided)
 B = 1/4" O.D. Freeze Resistant Cable
 C = 1/4" O.D. Plastic Tube (Bubbler Water Supply)
 D = 1/4" (6mm) DIA. Holes For Mounting Plate To Wall

CABLE SHEATH ADJUSTMENT

To Increase Free Play



To Reduce Free Play

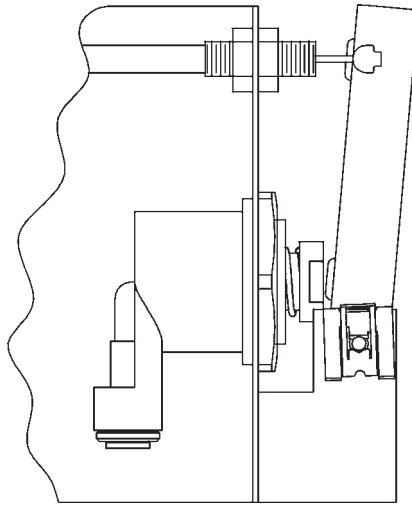

FIG. 7

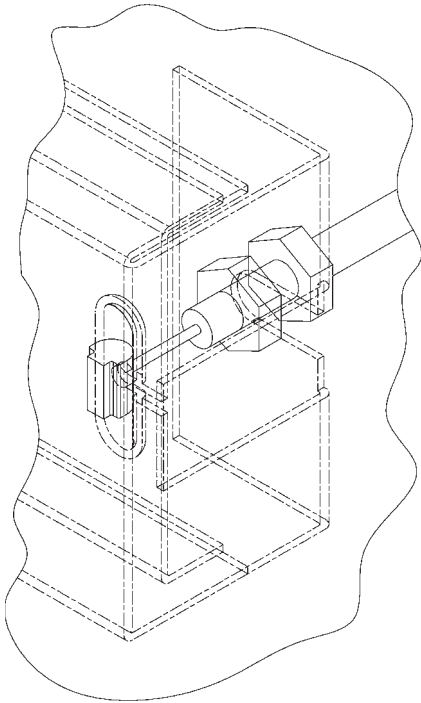

FIG. 8

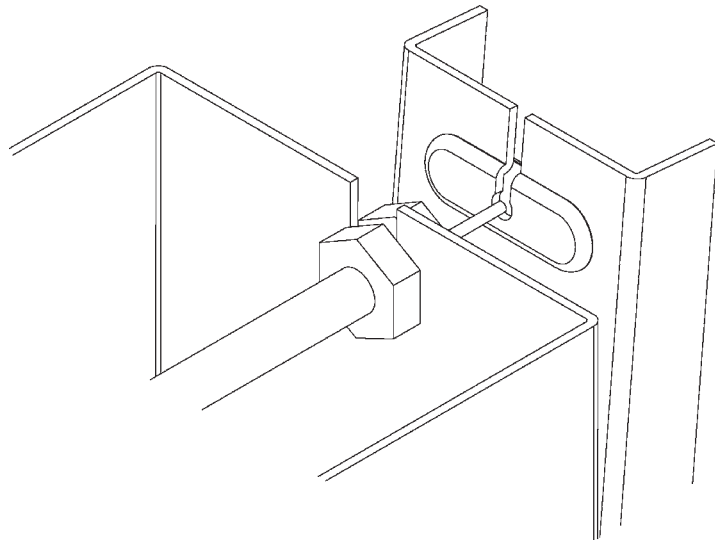

FIG. 9

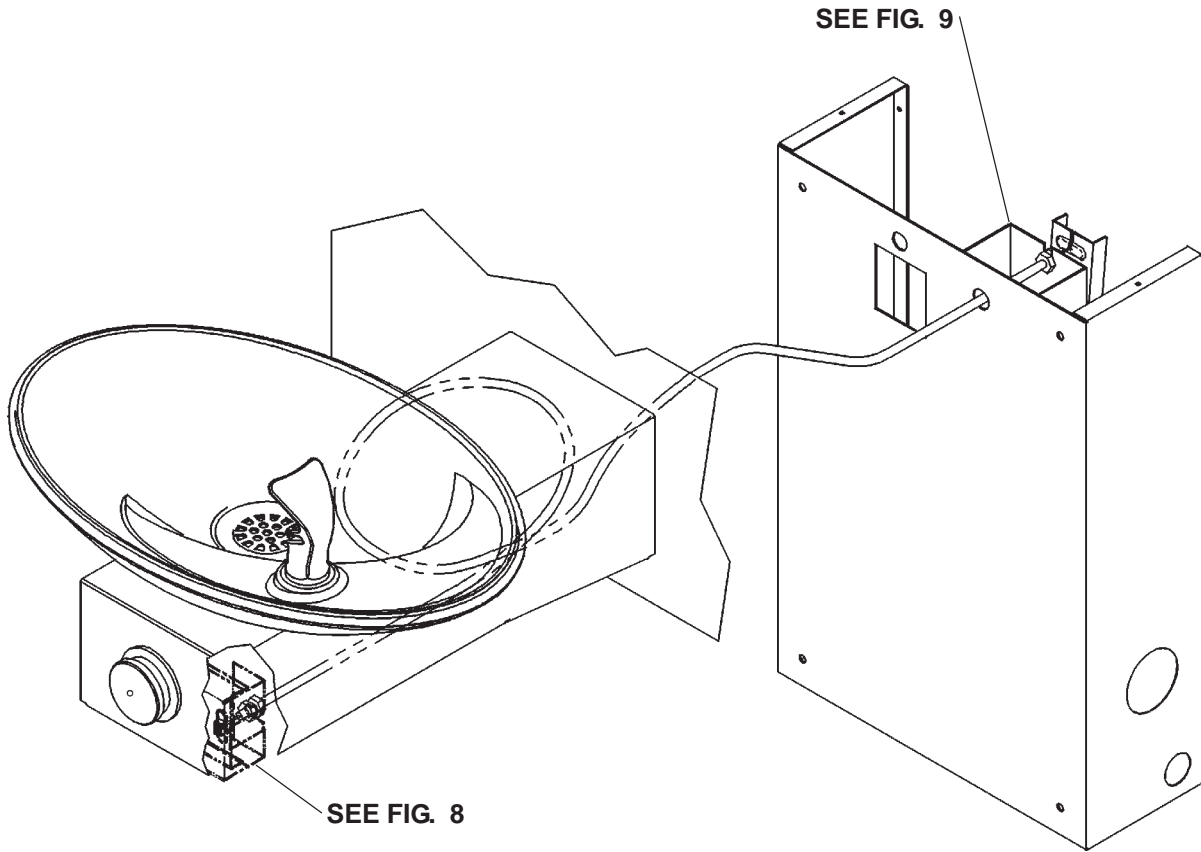

FIG. 10

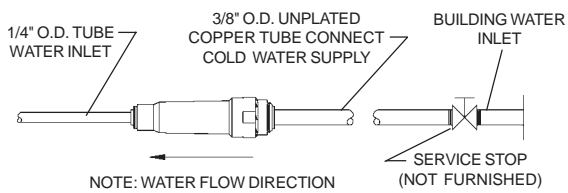

FIG. 11

OPERATION OF QUICK CONNECT FITTINGS

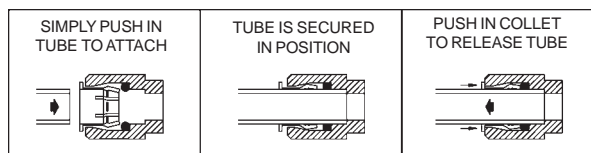

FIG. 12

PUSHING TUBE IN BEFORE PULLING IT OUT HELPS TO RELEASE TUBE.

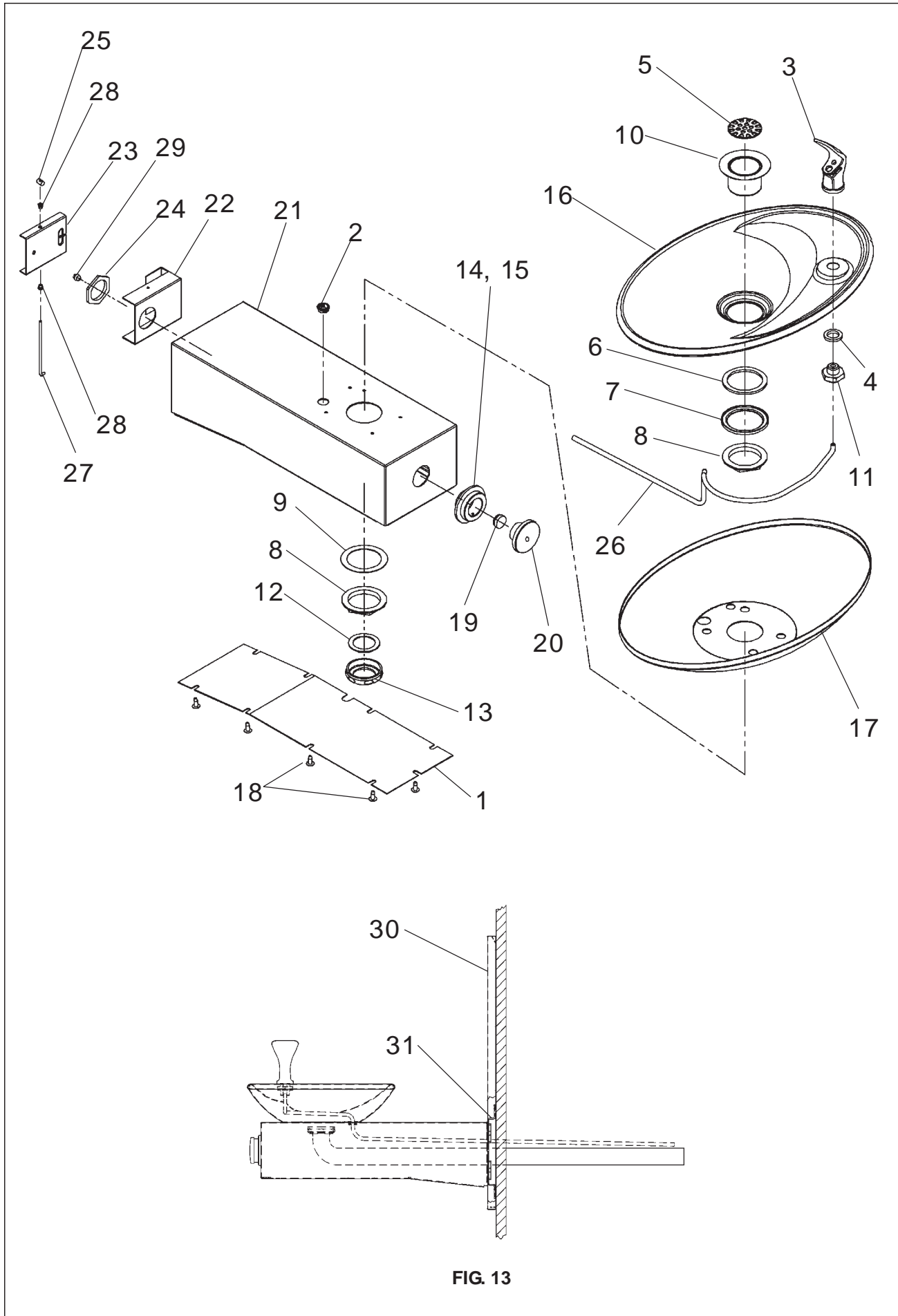

FIG. 13

OVLEBPFR, OVLSBPFR, OVLSEBPFR

PARTS LIST		
ITEM NO.	PART NO.	DESCRIPTION
1	27688C	Bottom Cover (OVL-S)
	27689C	Bottom Cover (OVL-E)
2	50595C	Bushing - Snap
3	51546C	Bubbler
4	100322740560	Gasket - Black
5	160270508640	Strainer Plate
6	101570540560	Drain Gasket
7	51575C	Packing Ring
8	110346220550	Lock Nut - 1-1/2"-11-1/2
9	101637451550	Friction Ring
10	161637308640	Drain Plug
11	15008C	Bubbler Nipple Assembly
12	100023340560	Gasket - Neoprene
13	161570808550	Slip Nut
14	45663C	Push Button Sleeve
15	75672C	Screw - Cap
16	27006C	Basin
17	27000C	Basin Liner
18	112627543890	Screw # 10-24 x 1/2" Long
19	55919C	Push Button Extension
20	45662C	Push Button
21	55001138	Arm (OVL-S-FR)
	55001139	Arm (OVL-E-FR)
22	27945C	Basin Bracket
23	27946C	Basin Pivot Bracket
24	40045C	Nut - Hex (unplated)
25	40206000	Retainer
26	56092C	Tube - Poly (cut to length)
27	70425C	Rod - Pivot
28	50198C	Bushing Snap
29	51468C	Bumper - Reg. Valve Assy
30	22797C	Back Panel (OVL-EBP)
	22799C	Back Panel (OVL-SBP)
	26958C	Back Panel (OVL-SEBP)
31	28120C	Wall Plate Assembly - OVL-SBP
	28121C	Wall Plate Assembly - OVL-SEBP
	28168C	Wall Plate Assembly - OVL-EBP
NS	45730C	Drain Tube
NS	75541C	Washer-Flat .339/.359ID Steel
NS	111577243890	Screw-Mach. 5/16-18 x 3/4" Long

TROUBLE SHOOTING AND MAINTENANCE

Orifice Assy: Mineral deposits on orifice can cause water flow to spurt or not regulate. Mineral deposits may be removed from the orifice with a small round file or small diameter wire. CAUTION: DO NOT file or cut orifice material.

Stream Regulator: If orifice is clean, regulate flow as in "STREAM HEIGHT ADJUSTMENT" instructions on pg 2. If replacement is necessary, see parts list for correct regulator part number.

Actuation of Quick Connect Water Fittings: Fountain is provided with lead-free connectors which utilize an o-ring water seal. To remove tubing from the fitting, relieve water pressure, push in on the gray collar while pulling on the tubing.(see Fig.12) To insert tubing, push tube straight into fitting until it reaches a positive stop, approximately 3/4".

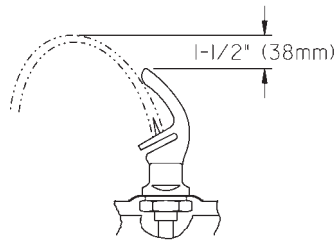

FIG. 14

Halsey Taylor

2222 CAMDEN COURT
OAK BROOK, IL 60523
630.574.3500

FOR PARTS CONTACT YOUR LOCAL DISTRIBUTOR OR VISIT OUR WEBSITE WWW.HALSEYTAYLOR.COM

PRINTED IN U.S.A.