

# Bubbler Valves

## Model 5052:

Self-closing, lever handle valve with adjustable stream regulation; integral, chrome plated brass basin shank; 1/2" O.D. slip joint supply. Vandal resistant pins prevent turning of fixture. This valve exceeds the standards of the Safe Drinking Water Act and Lead Contamination Control Act. All components in the waterway contain less than 0.1% lead. Dimensions: bottom of flange to top, 6 3/16"; shank length, 2 1/4"; flange dia., 2"; shank dia., 13/16". This valve has been discontinued and only component parts are available.

### Servicing Instructions for Model 5052:

If stream height of water is unsatisfactory, remove cap nut (15) and "O" ring (14) and adjust stream by turning slotted adjusting screw (13) clockwise to lower or turn off, counter clockwise to raise. If this fails to improve stream, or if valve is malfunctioning, replace damaged components with the VRK5832.

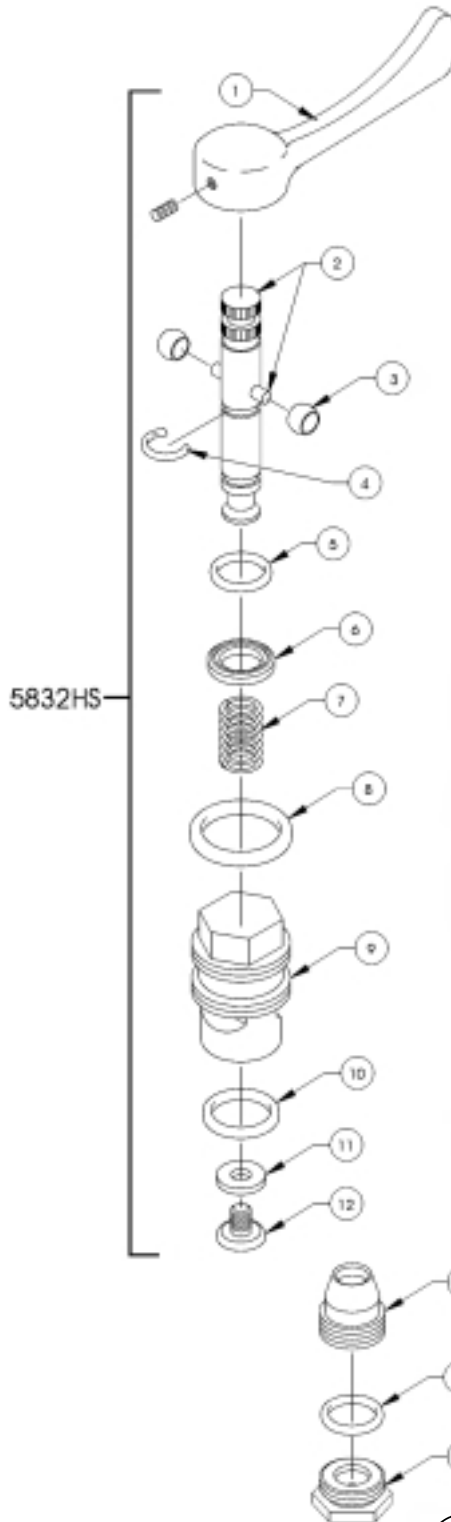
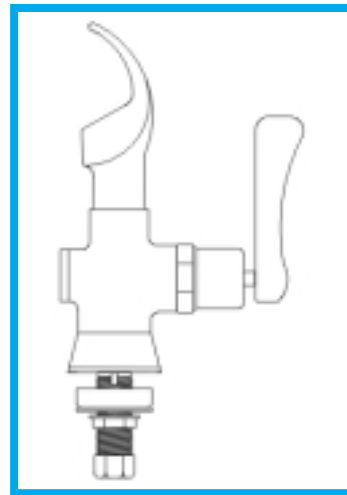

VRK5832

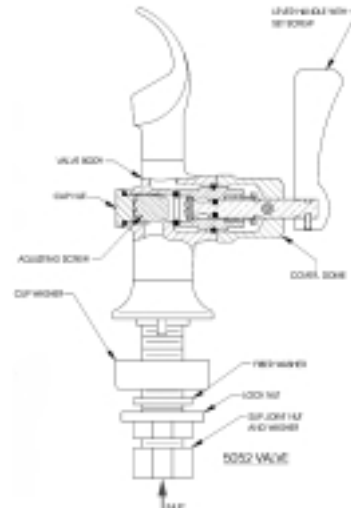
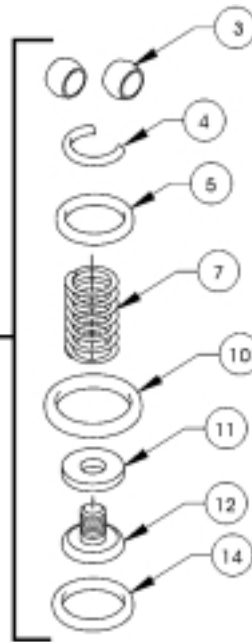

Repl. Part #	Item #	Description
5832HS (Includes items 1-12)		
0002689100	1	Handle Lever Blank with Set Screw
	2	Spindle with Pin
	6	Washer Retainer
	8	"O" Ring Cover
	9	Cover
VRK5832 (Includes items 3-5, 7, 10-12 and 14)		
	3	Roller (2 req'd)
	4	Circlip
	5	"O" Ring Spindle
	7	Spring
	10	"O" Ring Seal
	11	Washer Neoprene
	12	Screw, Seat Washer Retainer
0004694600	14	"O" Ring Cap Nut
0005183100	13	Screw Adjusting
0003869100	15	Nut, Cap

LEAD  FREE



Certified to NSF-61 Section 9