

In-line Strainers

Model 6420

Lead free, 60 micron, in-line, bowl-type strainer features positive rubber seals molded onto a fine mesh screen, and is included in most Haws drinking fountains. Located on the inlet side of the valve, this strainer provides protection from large debris and contaminants, 1/4" NPT(M) inlet and outlet. Strainer may be installed in-line using supplied 3/8" OD tubing connectors. This strainer exceeds the standards of the Safe Drinking Water Act and Lead Contamination Control Act. All components in the waterway contain less than 0.1% lead.



Service Instructions for Model 6420:

Unscrew cap from body and remove screen. Thoroughly rinse and clean screen to remove any residual debris. If screen is damaged, replace with the 6420RK. If strainer body is damaged replace the complete strainer.

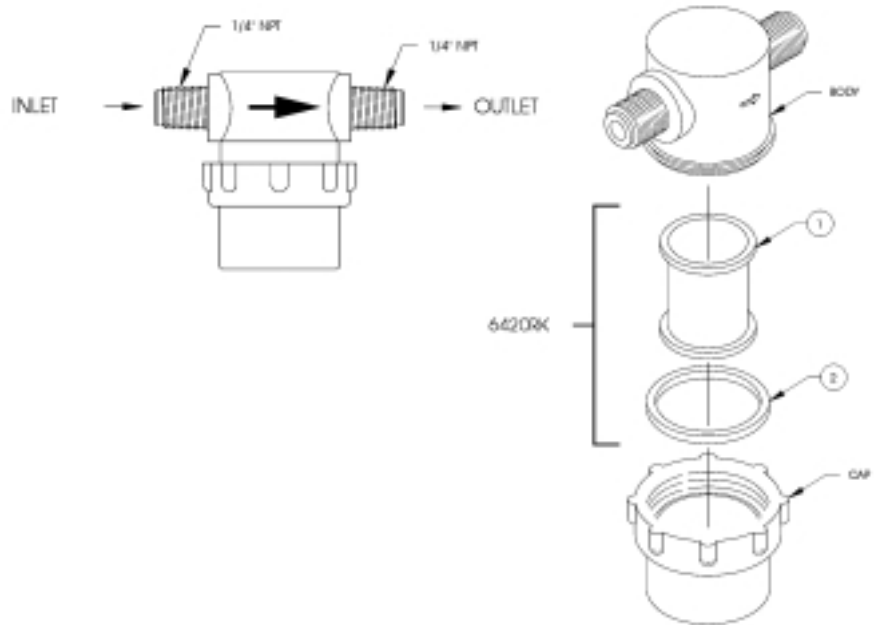

Repl. Part #	Item #	Description
6420RK	1	Screen
	2	Washer, Rubber

Model 6433

Lead free celcon body, Y pattern water strainer with removable 100 mesh screen for easy cleaning. 3/8" NPT(F) inlet and outlet. 1 7/8" long with strainer arm extended out to 2 5/16" overall width. This strainer exceeds the standards of the Safe Drinking Water Act and Lead Contamination Control Act. All components in the waterway contain less than 0.1% lead.

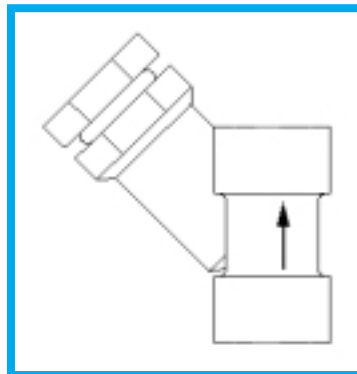

Service Instructions for Model 6433:

Unscrew hex plug, and remove strainer screen. Flush and clean thoroughly removing all debris. If screen is damaged replace complete strainer. Individual replacement parts are not available.

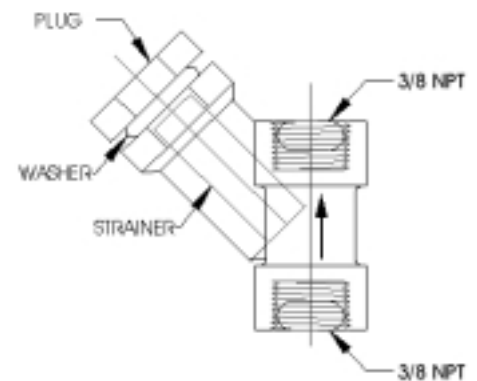

LEAD  FREE